



STÖBER

SERVO GEARED MOTORS



STOBER Synchronous Servo Geared Motors offer powerful performance in a compact size, making them the right fit for your application!



UP TO 45% REDUCTION IN LENGTH VERSUS THE COMPETITION!

Benefits of STOBER Geared Motor

- Optimize space for machine design
- Eliminate wear components
- Save money

DIFFERENT OPTIONS MEAN MORE SOLUTIONS!

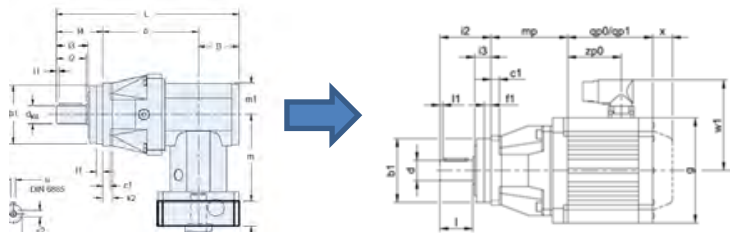
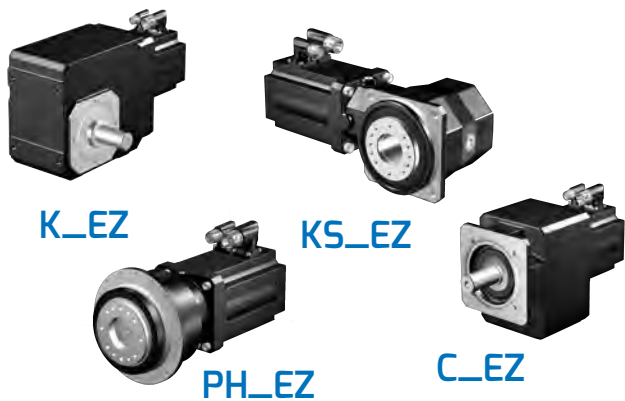

In some cases, an inline planetary geared motor is only marginally longer than the output section of a right-angle planetary. This can lead to both an overall space and cost savings in your application.

STOBER geared motors compared to competitor motors and the standard units used on them, as compared by the kW rating of the motor.

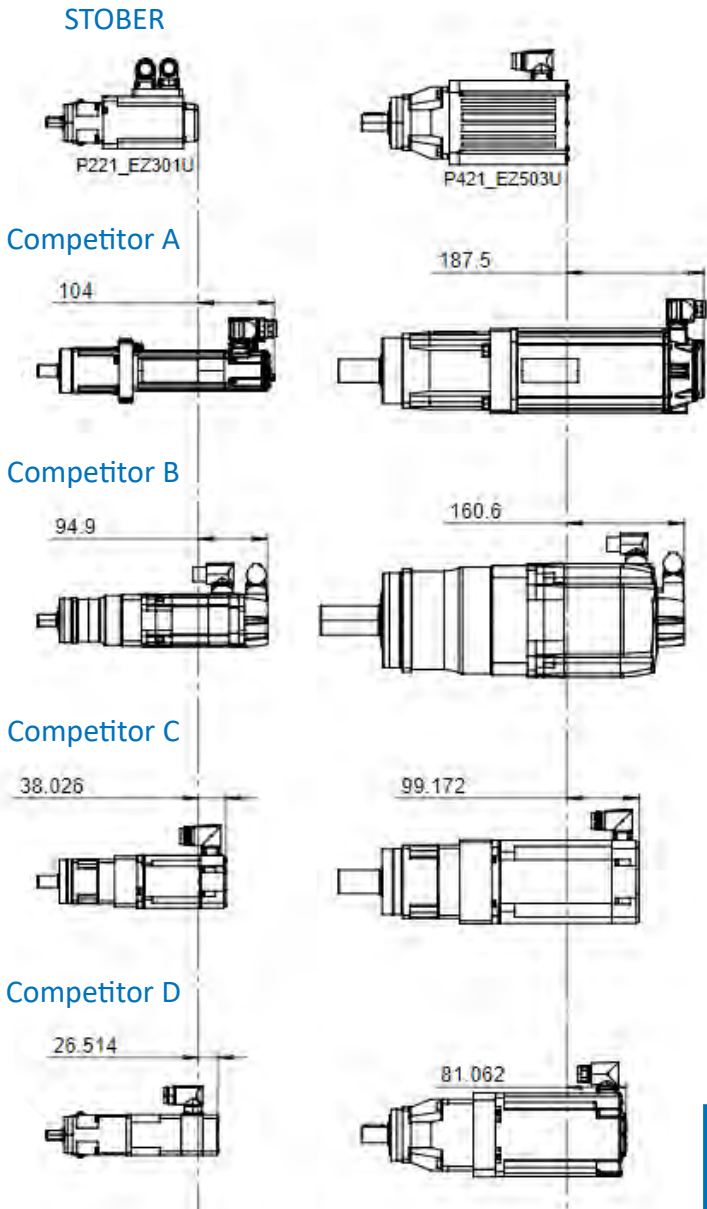



STÖBER

Our Three Pillars

STOBER is your **trusted partner** in providing the ultimate customer experience. From unsurpassed quality to rapid response support to fast delivery, we are the **gold standard** for gearboxes.



With the new STOBER Configurator, engineers and designers will save time in product selection and designing. Everything is a simple click away!



24/7 Support
Built in less than 1 week



Aftermarket Repair and Replacement done in USA



Committed to **optimizing your production** and machine design



MORE COMPACT



ADAPTABILITY



PACKAGED UNIT



MORE DYNAMIC



RUNS COOLER